

E1010 INDICATOR



- ▷ Stainless steel enclosure (washdown safe)
- ▷ Fast-reading light emitting digits
- ▷ Numeric keypad
- ▷ Multiple print formats
- ▷ Easy operation for all-purpose weight measurement
- ▷ Two RS-232 ports

Includes the versatility of optional battery operation for mobile applications.

THE evolution SERIES

The Power of Intelligence

Enclosure Integrity & Enhanced Readability

The Avery Weigh-Tronix Indicator E1010 features an exclusive stainless steel enclosure with a NEMA 6/4X rating from Underwriters Laboratory (UL), the highest ratings ever given to a weight indicator. This exceptional rating is due to the Model E1010's imperviousness to moisture and resistant to washdown pressure. It is ideal for food and manufacturing industries as well as wet, dry, indoor and outdoor environments.

The Model E1010 also features new light emitting display technology with large digits (0.8 inch) providing superior readability. The lighted digital readout is projected clearly making it easily seen from a distance or in dim, steamy- or dust-prone indoor environments.

Specialized Applications

Numeric Keypad: makes TARE and numeric ID entry easy. The numeric keypad lets you store multiple TAREs and numeric IDs in memory for easy retrieval. Enter eight known weights from the keypad or use the TARE key to enter container weights.

Multiple Print Formats: allow pre-defined print layouts with weight details or other messages to be recalled using the keypad.

Easy Operation for All-Purpose Weighing: makes the Model E1010 ideal for bench scales, floor scales and tank weighing applications in many industries including food, manufacturing, truck weighing and more.



Rigorous NEMA 6/4X enclosure with easily viewed lighted digits.

General Weighing: weightments can be accumulated, stored and recalled including number of transactions.

Checkweighing: display includes a multi-segment fan graph for fast evaluation so operators can instantly verify that products are within target ranges or above or below acceptable tolerance.

Counting routines: for display of piece number or average piece weight along with gross, net or tare weights.

Peak weight: so if a maximum weight reading is required, it can capture and display the peak measurement of stable weights.

Process control: equipped with three setpoint controls to interface with relays for automated mixing or blending operations.

Added Performance Features

- ▷ The Model E1010 can serve as a remote display in applications where weights must be read in two locations to display weight annunciators, units of measure, or use of function keys.
- ▷ Weight information can be transmitted to peripheral printers and/or computers through the indicator's communication port. Information format may be customized and can include time and date.
- ▷ An optional internal battery provides mobility for cart-mounted bench scales or applications where AC power is not available. The internal battery automatically recharges when the indicator is connected to a main power source.
- ▷ An optional washdown remote foot control can be added for improved efficiency in common lift and weigh applications, giving the operator hand-free control of common scale functions (zero, print or tare).

Avery Weigh-Tronix

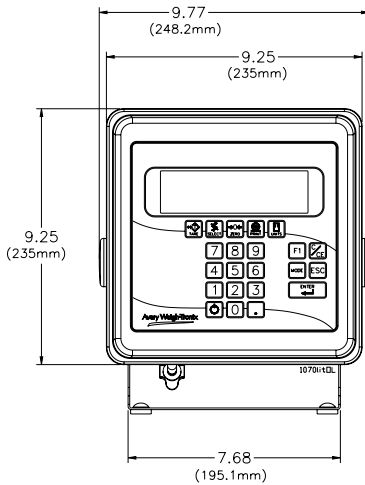

Front View and Dimensions

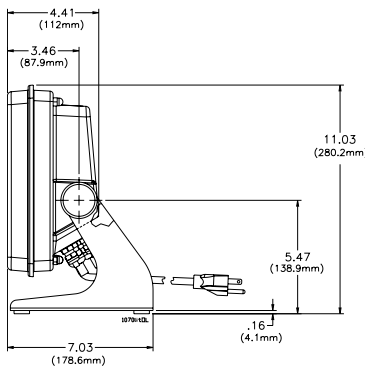

Side View and Dimensions

Power requirements

- 100-240 Volts AC @ 600 mA
- 50/60 Hz
- **Optional Internal battery:** 23 hours of continuous operation with one weight sensor; 15 hours of continuous operation with four weight sensors
- Standby mode extends battery life

Excitation

- 5 volts DC
- Supports up to four 350-ohm weight sensors

Analog signal input range

- 12 mV/V

Analog input sensitivity

- 0.5 μ V/divisions minimum

Calibration

- 2 to 5 points stored

Operational keys

- **Twenty-two keys:** Tare, Select, Zero, Print, Units, F1, Clear, Mode, Escape, Enter
- On/Off, 0-9 numeric and decimal point

Operational annunciators

- Center of Zero, Motion, Gross, Tare, Net, Battery status
- Under/Target/Over
- Units of measure (LB, KG)
- Peak, Print, OP1, OP2, OP3

Display

- Seven-digit, seven-segment, 0.8-inch high
- Lighted STN Transmissive

Display rate

- Selectable (1, 2, 5, 10)

Analog to digital conversion rate

- 60 times per second

Unit of measure:

- Three, independently programmable
- Pounds, Kilograms, Custom

Capacity selections

- 999,999 with decimal located from zero to five places

Incremental selections

- Multiples and sub-multiples of 1, 2, 5

Programmable selections

- Zero range, motion detection, automatic zero tracking, five-point linearization

Time and date/RAM

- Battery backed up real time clock and RAM

Internal resolution

- 64,424,509 counts per mV/V per sec

Standard inputs

- **Three logic level inputs for:** Zero, Print, Tare, Units, F1

Standard outputs

- Three cutoff outputs, open collector design

Two serial ports

- RS-232/422/485/20mA currents selectable
- RS-232

Serial command inputs

- Programmable serial response to ASCII character input
- SMA protocol, broadcast, enquire, RD-4100, E-Series remote display

Self diagnostics

- Display, keys, inputs, outputs, serial port,

Circuitry protection

- RFI, EMI, and ESD protection

Options

- Trips Interface Unit (TIU3)
- Wash down remote foot control

Operating applications

- General weighing, Accumulation, Simple counting, Checkweighing, Peak measurement, Batching, Remote display

Operating temperature

- 14 to 104° F (-10 to 40° C) NTEP
- -4 to 140° F (-20 to 60° C) non-legal
- 10 to 90% noncondensing humidity

Enclosure

- Stainless Steel NEMA 6/4X, IP67

Dimensions

- 9.25" W x 9.25" H x 4.5" D (without mounting bracket)
- 9.75" W x 11" H x 7" D (with mounting bracket)

Weight

- 11 lb, 5 kg

Agencies

- NTEP CC# 04-029
Class III/IIIL: 10,000 divisions
- OIML Certificate Number R76/1992-GBI-04.09
Class III: 10,000 divisions
- Canadian Weights and Measures pending
- UL/CUL
- CE marked

AUTHORIZED DISTRIBUTORS

Avery Weigh-Tronix distributors are complete support centers, providing needs assessment, technical information, product sales and service. Call or visit www.wtxweb.com for your nearest Avery Weigh-Tronix distributor.

Avery Weigh-Tronix



Fairmont, Minnesota U.S.A.

USA Toll-free: 800-368-2039

USA Phone: 507-238-4461

www.wtxweb.com

Specifications are subject to change in accordance with technical modification.

4/06 E1010_spec.indd (C&D) PNO9961-0016B

Pointe Claire, Quebec Canada

CAN Toll-free: 800-561-9461

CAN Phone: 514-695-0380

www.weigh-tronix.ca