

## SURVIVOR® CW-80 Over/Under Checkweigher



### Approvals



Measurement  
Canada  
Approved

Meets USDA  
Requirements

### Standard Features

- Industrial-quality 304 stainless steel construction
- Rugged five-point overload protection on platform bases
- LifeGuard shock-absorbing bases on 6 lb to 100 lb capacities in base sizes up to 12" x 12"
- Highly-durable and corrosion-resistant stainless steel load cell on 6 lb to 60 lb capacities
- Field-proven aluminum load cell on 100 lb to 1,000 lb capacities
- NEMA 4X/IP66 indicator enclosure
- ToughTouch industrial touch-control front panel with keys for over, under, tare, zero, units, print, target and ID
- Front-panel "Independent Key Disabling" for: OVER, UNDER, TARE, PRINT and UNITS keys
- Displays units in decimal lb, kg, oz, lb & oz, g
- High-intensity LED for over, under and accept
- Storage for up to 300 tare and tolerance settings
- Automatic zero tracking
- 115 or 230 VAC operation
- Full duplex RS-232 and/or simplex 20mA current loop communication

### Specifications

#### DISPLAY:

Large 0.8" 7-segment, 6-digit high-intensity red LED display, Decimal point available at each digit

#### STATUS ANNUNCIATORS:

lb, kg, g, oz, net, motion, center of zero, neg

#### KEYBOARD:

Eight-key touch control with international symbols

#### BAR GRAPH:

Five-segment, 7-range programmable multicolored array tracks Over, Under, Accept status in relation to target value

#### INTERNAL RESOLUTION:

50,000 to 1 million based on filtering selection

#### DISPLAY RESOLUTION:

Selectable up to 50,000 dd

#### MEASUREMENT RATE:

25 updates/second

#### SYSTEM LINEARITY:

0.01% of F.S.

#### ZERO STABILITY:

100 nV/°C maximum

#### SPAN STABILITY:

3ppm/°C maximum

#### AZM (ZERO TRACK):

off, ±.5, 1, 2 or 3 dd

#### OPERATIONAL AZM:

±2% or 100% F.S

#### MOTION BAND:

Off, .5, 1, 2, 3, 5, 10 dd

#### CALIBRATION METHOD:

Software

#### EXCITATION VOLTAGE:

10 ± .05 VDC, 4 x 350 ohms load cell

#### DIGITAL FILTER:

Software selectable 1, 2, 4, 8, 16, 32, 64, 128

#### SENSE AMPLIFIER:

Differential amplifier with 6-wire sensing

#### RFI PROTECTION:

Signal, excitation and sense lines protection. 33V/m for 100 kHz to 1 GHz, ≤1 μV susceptibility

#### DIGITAL OUTPUTS:

(Optional) 3 TTL outputs (5VDC) or 3 N/O relays (10 watts, 0.5 amp, 100 VDC) or 3 N/C relays to (10 watts, 0.5 amp, 100 VDC)

#### EPD PORT:

Full duplex, RS-232 or 20 mA simplex output (RS-485 optional)

#### LINE VOLTAGES:

Available in 115 or 230 VAC (nom.) models

#### FREQUENCY:

50 or 60 Hz

#### OPERATING TEMPERATURE:

14°F to 104°F (-10°C to 40°C)

#### INDICATOR DIMENSIONS:

9.5" W x 8.5" H x 3.25" D  
(241 mm x 216 mm 83 mm)

#### APPROVALS:

System approved to 3,000 divisions, NTEP-certified per H-44; Indicator, 10,000d, Class III/IIIL, CC #96-118A1, Base, CC #96-107. Measurement Canada approved: Indicator, AM-5146, Base, AM-5156, OIML certificate #R76/1992-DE-97.02, UL & C-UL listed, CE marked

#### WARRANTY:

Two-year limited warranty

#### OVERALL DIMENSIONS (APPROX):

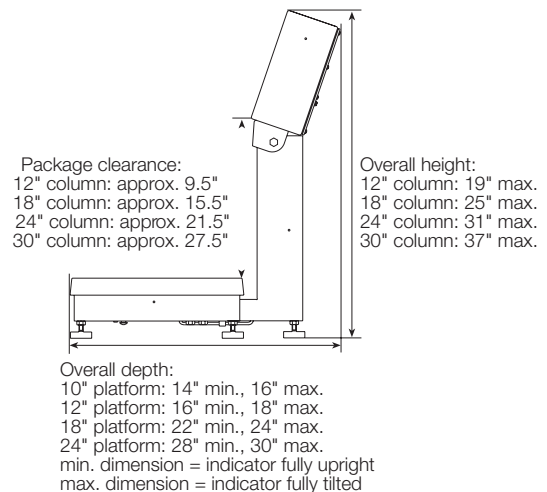

# SURVIVOR® CW-80 Checkweigher

PART #	CAPACITY	PLATFORM DIMENSIONS	COLUMN HEIGHT	EST. SHIP WEIGHT	PRICE
35113	6 lb x .002 (3 kg x .001) 96 oz x .05	10" x 10" x 3"	12"	20 lb	\$1,515.00
35114	10 lb x .005 (5 kg x .002) 160 oz x .1	10" x 10" x 3"	12"	20 lb	1,515.00
35115	15 lb x .005 (7 kg x .002) 240 oz x .1	10" x 10" x 3"	12"	20 lb	1,515.00
35116	30 lb x .01 (15 kg x .005) 480 oz x .2	10" x 10" x 3"	12"	20 lb	1,515.00
35121	30 lb x .01 (15 kg x .005) 480 oz x .2	12" x 12" x 3"	12"	23 lb	1,625.00
35122	60 lb x .02 (30 kg x .01) 960 oz x .5	12" x 12" x 3"	12"	23 lb	1,625.00
35175	100 lb x .02 (50 kg x .01) 1,600 oz x .5	12" x 12" x 3"	12"	23 lb	1,625.00
35176	100 lb x .02 (50 kg x .01) 1,600 oz x .5	18" x 18" x 5.25"	18"	78 lb	2,135.00
35177	200 lb x .05 (100 kg x .02) 3,200 oz x 2	18" x 18" x 5.25"	18"	78 lb	2,135.00
35178	300 lb x .1 (150 kg x .05) 4,800 oz x 2	18" x 18" x 5.25"	18"	78 lb	2,135.00
35179	500 lb x .1 (250 kg x .05) 8,000 oz x 2	18" x 18" x 5.25"	18"	78 lb	2,135.00
35181	200 lb x .05 (100 kg x .05) 3,200 oz x 2	24" x 18" x 5.25"	18"	95 lb	2,385.00
35182	300 lb x .1 (150 kg x .05) 4,800 oz x 2	24" x 18" x 5.25"	18"	95 lb	2,385.00
35183	500 lb x .1 (250 kg x .05) 8,000 oz x 5	24" x 18" x 5.25"	18"	95 lb	2,475.00
35184	1000 lb x .2 (500 kg x .1) 1,6000 oz x 5	24" x 18" x 5.25"	18"	95 lb	2,475.00
35185	200 lb x .05 (100 kg x .02) 3,200 oz x 1	24" x 24" x 5.25"	18"	110 lb	2,475.00
35186	300 lb x .1 (150 kg x .05) 4,800 oz x 2	24" x 24" x 5.25"	18"	110 lb	2,475.00
35187	500 lb x .1 (250 kg x .05) 8,000 oz x 2	24" x 24" x 5.25"	18"	110 lb	2,585.00
35188	1000 lb x .2 (500 kg x .1) 16,000 oz x 5	24" x 24" x 5.25"	18"	110 lb	2,585.00
<b>KG only (230 VAC)</b>					
66682	3 kg x .001	10" x 10" x 3"	12"	20 lb	1,515.00
66681	5 kg x .002	10" x 10" x 3"	12"	20 lb	1,515.00
66680	7.5 kg x .005	10" x 10" x 3"	12"	20 lb	1,515.00
68667	7.5 kg x .005	10" x 10" x 3"	3"	20 lb	1,515.00
<b>OIML Certified (230 VAC)</b>					
51200	30 lb x .01 (15 kg x 0.005) 480 oz x .2	10" x 10" x 3"	12"	20 lb	1,515.00
51201	30 lb x .01 (15 kg x 0.005) 480 oz x .2	12" x 12" x 3"	12"	23 lb	1,625.00
51202	60 lb x .02 (30 kg x 0.01) 960 oz x .5	12" x 12" x 3"	12"	23 lb	1,625.00
<b>Options/Accessories</b>					
<b>Electronics</b>					
Option A	230 VAC operation				No Extra Charge
<b>Outputs</b>					
Option B	3 TTL level setpoints				205.00
Option C	3 normally-open relays				225.00
Option D	3 normally-closed relays				225.00
<b>Software</b>					
Option H	RS-485 communication (factory installable only)				195.00
<b>Hardware</b>					
Option I**	12" indicator column replacing standard column				No Extra Charge
Option J**	18" indicator column replacing standard column				No Extra Charge
Option K**	24" indicator column replacing standard column				25.00
Option L**	30" indicator column replacing standard column				35.00
Option M	Combination desk/wall mount bracket replacing std column				No Extra Charge
Option P	304 stainless steel clamshell load cell protection (12" x 12", 100 lb capacity only)				75.00
41292	304 stainless steel clamshell load cell protection (18" x 18" - 24" x 24")				90.00
18805	304 stainless steel clamshell for added load cell protection (18" x 18", 18" x 24" and 24" x 24"), 1,000 lb capacity only				100.00
32291	Additional operating manual				15.00
33752	Supervisor's operating guide (includes operator's card)				10.00

Please consult factory if your application requires hermetically sealed load cells

\*\* If ordering the column without a scale, refer to the replacement parts catalog for necessary part numbers and pricing